

VACUUM PUMPS VTL 25/FG, 30/FG and 35/FG WITH DISPOSABLE LUBRICATION



These vacuum pumps have a suction capacity of 25, 30 and 35 cum/h. The vacuum lubrication with oil recirculation is adjusted via two oilers located in correspondence of the support bearings.

The rotor is cantilevered-fitted on the motor shaft and supported by independent bearings housed in the two pump flanges.

The pump and the electric motor are, therefore, two independent units and fixed onto a special support and connected to each other via an elastic transmission joint.

All this allows using standard electric motors, in the shapes and sizes indicated in the table.

The pump is surface cooled. Heat is dispersed from the outer surface, suitably finned, by means of a radial fan placed between motor and pump.

An oil recovery tank is installed on the pump exhaust. This tank contains a separator filtre that prevents oil mists and reduces noise.

A safety valve is also installed on the tank for the automatic drainage of the exhaust oil when not regularly drained.

The lubrication oil is contained in a special transparent container, fixed to the pump via its support, and controlled by a magnetic level switch.

In pumps with disposable lubrication, the oil is sucked in the pump through an adjustable drip oiler and drained together with the sucked air in the recovery tank, without being put in circulation again. These pumps are necessary when the air to be sucked contains water condensation, solvent vapours or anything else that could effect oil properties.

We strongly recommend installing a check valve and a filtre on the suction inlet.

These pumps are supplied with three-phase electric motors only.

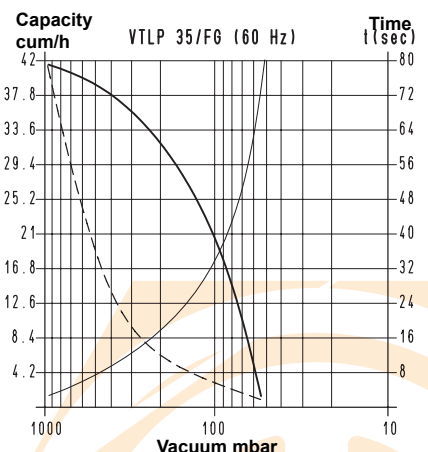
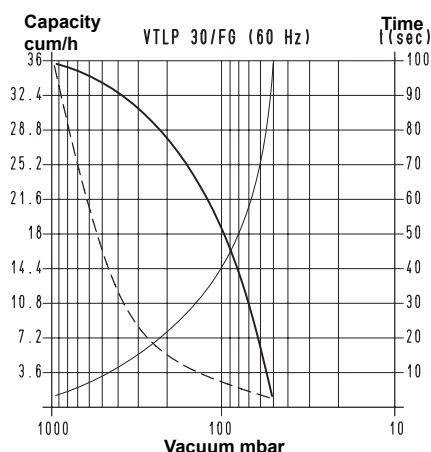
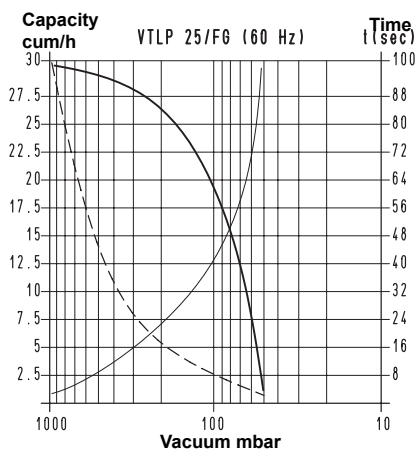
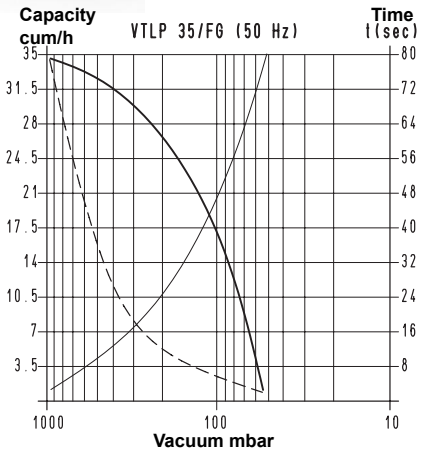
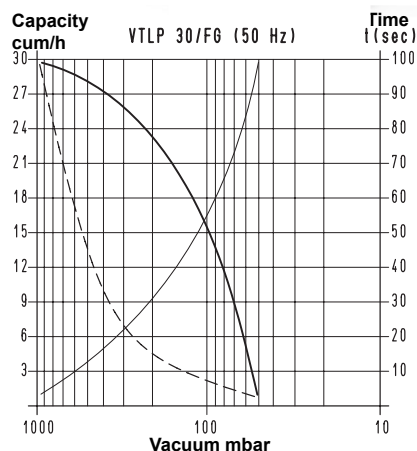
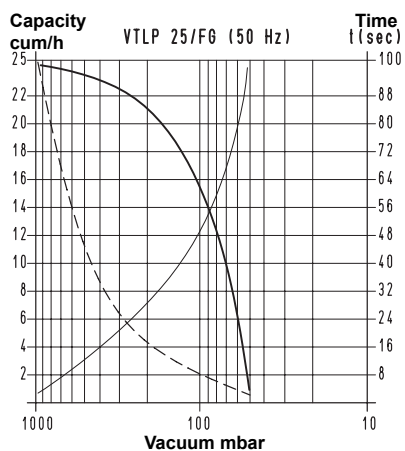

To calculate the emptying time of a volume V_1 , apply the formula $t_1 = \frac{t \times V_1}{100}$

V_1 : Volume to be emptied

t_1 : Time to be calculated (sec)

t : Time obtained in the table (sec)

- Curve regarding capacity (referring to the suction pressure)
- - - Curve regarding capacity (referring to a 1013 bar pressure)
- · · Curve regarding the emptying of a 100-litre volume

3D drawings available at www.vuototecnica.net

VACUUM PUMPS VTLP 25/FG, 30/FG and 35/FG

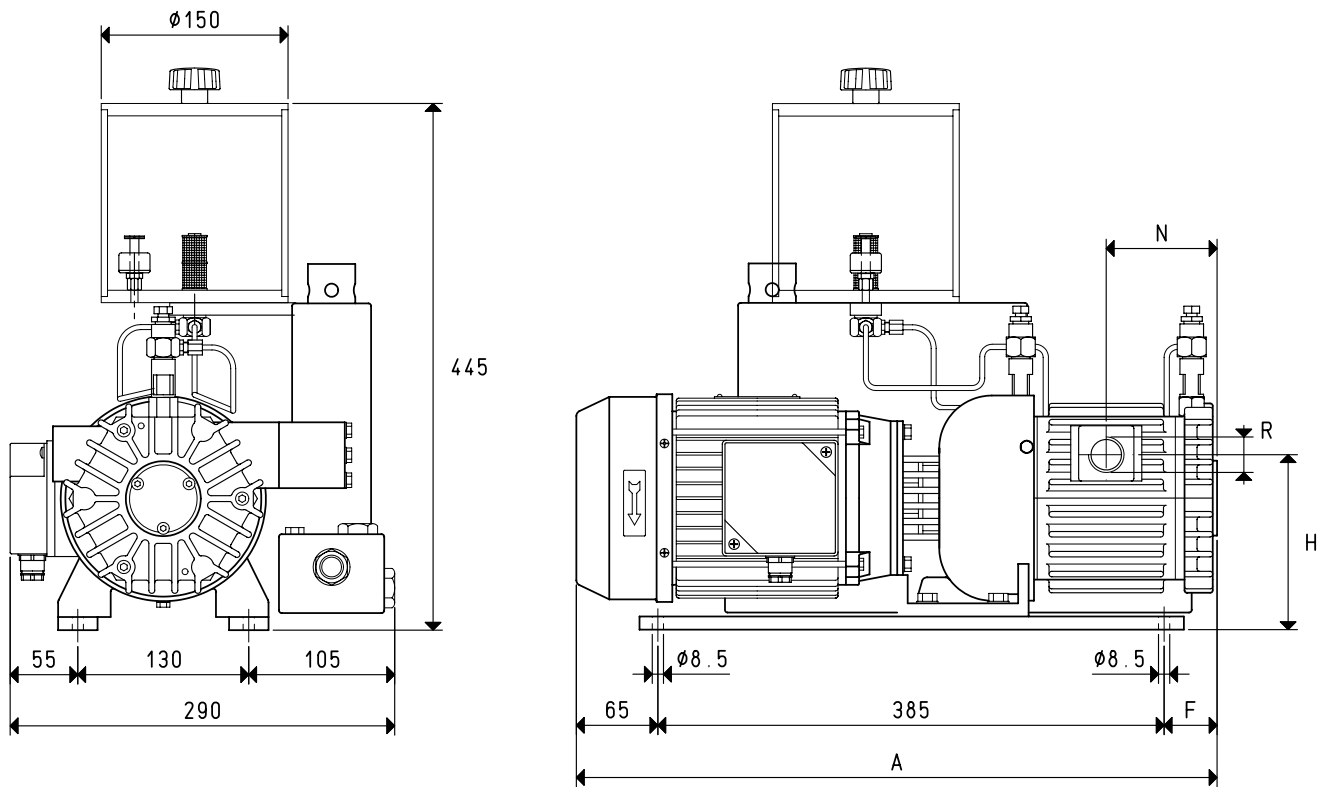

Art.	VTLP 25/FG		VTLP 30/FG		VTLP 35/FG	
	50Hz	60Hz	50Hz	60Hz	50Hz	60Hz
Frequency	50Hz	60Hz	50Hz	60Hz	50Hz	60Hz
Capacity m ³ /h	25.0	30.0	30.0	36.0	35.0	42.0
Final pressure mbar abs.	50		50		50	
Motor execution 3~	230/400±10%	275/480±10%	230/400±10%	275/480±10%	230/400±10%	275/480 ±10%
Volt						
Motor power 3~	0.88	1.05	1.00	1.20	1.00	1.20
Kw						
Motor protection IP	54		54		54	
Rotation speed rev/min ⁻¹	1450	1740	1450	1740	1450	1740
Motor shape	B14		B14		B14	
Motor size	80		80		80	
Noise level dB(A)	64	66	65	67	65	67
Max. weight 3~	32.0		36.0		38.0	
Kg						
A	470		490		510	
F	20		40		60	
H	133		133		133	
N	73		83		93	
R Ø gas	G3/4"		G3/4"		G3/4"	
Accessories and spare parts						
Oil load l	1.8		1.8		1.8	
Synthetic oil VT OIL	ISO 68		ISO 68		ISO 68	
6 vanes art.	00 VTL 25FG 10		00 VTL 30FG 10		00 VTL 35FG 10	
Sealing kit art.	00 KIT VTL 25FG		00 KIT VTL 30FG		00 KIT VTL 35FG	
Check valve art.	10 04 10		10 04 10		10 04 10	
Suction filtre art.	FB 25/FC 25		FB 25/FC 25		FB 25/FC 25	
Oil level switch art.	00 LP VTL 99		00 LP VTL 99		00 LP VTL 99	
Oil filtre art.	00 LP VTL 40		00 LP VTL 40		00 LP VTL 40	
Adjustable drip oiler art.	00 VTL 00 11		00 VTL 00 11		00 VTL 00 11	

3D drawings available at www.vuototecnica.net